

Dimension

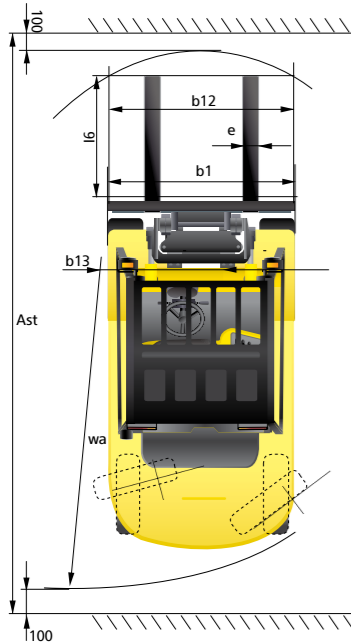
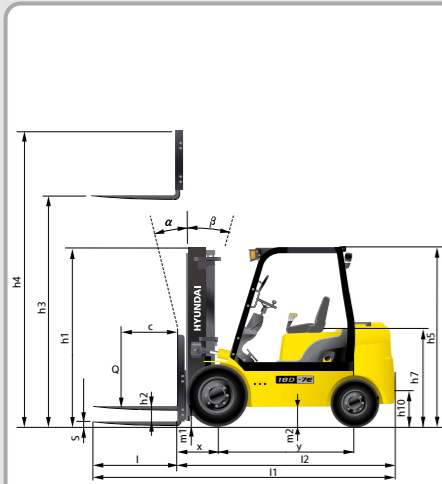

Specification

Identification				
1.1	Manufacturer		Hyundai	Hyundai
1.2	Manufacturer's type designation		15D-7E	18D-7E 20DA-7E
1.3	Drive: electric (battery or mains), diesel, petrol, fuel gas, manual		DIESEL	DIESEL DIESEL
1.4	Type of operation: hand, pedestrian, standing, seated, order-picker		seated	seated seated
1.5	Load capacity / rated load	kg	1,500	1,750 2,000
1.6	Load center distance	c mm	500	500 500
1.8	Load distance, center of drive axle to fork	x mm	393	393 398
1.9	Wheelbase	y mm	1,410	1,410 1,410
Weights				
2.1	Service weight	kg	2,800	2,970 3,116
2.2	Axle loading, loaded front/rear	kg	3,740 / 560	4,103 / 617 4,478 / 643
2.3	Axle loading, unloaded front/rear	kg	1,290 / 1,510	1,245 / 1,725 1,200 / 1,916
Wheels, Chassis				
3.1	Tires: solid rubber, superelastic, pneumatic, polyurethane		pneumatic	pneumatic pneumatic
3.2	Tires size, front		6.50-10-12PR	6.50-10-12PR 6.50-10-12PR
3.3	Tires size, rear		5.00-8-10PR	5.00-8-10PR 5.00-8-10PR
3.5	Wheels, number front x rear (x=driven wheels)		x2 / 2	x2 / 2 x2 / 2
3.6	Track width, front	mm	890	890 890
3.7	Track width, rear	mm	910	910 910
Basic Dimensions				
4.1	Mast / fork carriage tilt forward / backward (α/β)	degrees	6 / 10	6 / 10 6 / 10
4.2	Lowered mast height	h1 mm	2,155	2,155 2,155
4.3	Free lift	h2 mm	145	145 150
4.4	Lift height	h3 mm	3,325	3,325 3,330
4.5	Extended mast height	h4 mm	4,332	4,332 4,342
4.7	Overhead guard (cab) height	h5 mm	2,110	2,110 2,110
4.8	Seat height / standing height	h7 mm	1,127	1,128 1,128
4.12	Coupling height	h10 mm	271	271 270
4.19	Overall length	l1 mm	3,133	3,163 3,208
4.20	Length to face of forks	l2 mm	2,233	2,263 2,308
4.21	Overall width	b1 mm	1,070	1,070 1,070
4.22	Fork dimensions (hook type)	s / e / l mm	900 x 100 x 35	900 x 100 x 35 900 x 100 x 40
4.23	Fork carriage ISO 2328, class / type A,B		2A	2A 2A
4.24	Fork-carriage width	b12 mm	980	980 980
4.31	Ground clearance, loaded, under mast	m1 mm	120	120 120
4.32	Ground clearance, centre of wheelbase	m2 mm	143	142 140
4.33	Aisle width for pallets 1,000x1,200 crossways (LxW)	Ast mm	3,594	3,621 3,662
4.34	Aisle width for pallets 800x1,200 lengthways (WxL)	Ast mm	3,794	3,821 3,862
4.35	Turning radius	Wa mm	2,000	2,027 2,063
4.36	Smallest pivot point distance	b13 mm	589	589 589
Performance Data				
5.1	Travel speed, unloaded	km/h	19.0	19.0 19.1
5.2	Lift speed, loaded/ unloaded	mm/sec	620 / 650	620 / 650 620 / 650
5.3	Lowering speed, loaded/unloaded	mm/sec	500 / 450	500 / 450 500 / 450
5.6	Max. Drawbar pull, loaded	N	15,722	15,811 15,935
5.7	Gradient performance, loaded/ unloaded	%	36.9 / 24.5	33.1 / 22.2 30.9 / 20.5
5.9	Acceleration time, loaded/ unloaded (10m)	sec	NA	NA NA
5.10	Service brake		FOOT	FOOT FOOT
Engine				
6.1	Engine manufacturer / type		KUBOTA V2203	KUBOTA V2203 KUBOTA V2203
6.2	Engine power acc. to ISO 1585	kw	30.8	30.8 30.8
6.3	Rated speed	1/min	2,400	2,400 2,400
6.4	No. of cylinder / cubic capacity	anz/cm ³	4 / 2,197	4 / 2,197 4 / 2,197
6.5	Fuel consumption acc. to VDI cycle	ℓ / h	2	2 2
Other Details				
8.1	Type of drive control		power shift	power shift power shift
8.2	Operating pressure (MAIN / SECONDARY)	bar	187 / 147	187 / 147 187 / 147
8.3	Oil volume	ℓ	60	60 60
8.4	Sound level at driver's ear according to (DIN 12 053)	db(A)	88	88 84

1) with DZ mast +25mm; with integrated sideshift x=375mm(with DZ mast +25mm); with hook-on sideshift x=410.5mm(with DZ mast +25mm)



*Some of the photos may include optional equipment.

MOVING YOU FURTHER

HYUNDAI MATERIAL HANDLING Environmentally - Friendly

15D/18D/20DA-7E

Contact your Hyundai dealer for more information. The machine shown may vary according to International standards.
All US measurement rounded off to nearest pounds or inches.



Head Office (Sales office)

First tower, 55, Bundang-ro, Bundang-gu, Seongnam-si, Gyeonggi-do, Korea

PLEASE CONTACT

www.hyundai-mh.com

2020. 09 Rev.8



15D/18D/20DA -7E

New criterion of Forklift Trucks

Hyundai introduces a new line of 7E-series diesel forklift trucks. Excellent power and performance makes your business more profitable.

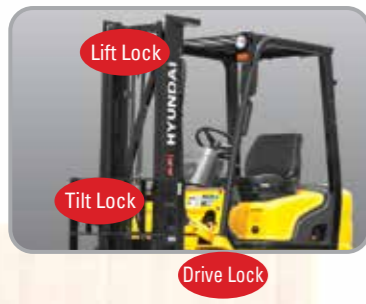

OPSS (Operator Presence Sensing System)
 Control of mast tilting, lifting and lowering is not possible through operation of the appropriate control when the operator is not in the normal position. (Option)



*Some of the photos may include optional equipment.

High Power & Performance

Powerful Engine

KUBOTA V2203 Engine

Market approved quality of Kubota V2203 engine ensures incomparable performance, durability and additional value to the machine. 30.8kW of the engine is more than enough to suit any work, not just with normal 30.8kW but with special attachments requiring high power as well.

(EPA / Tier-3 Certified)

30.8kW/2,300rpm



State-of-the-art hydraulic system

The latest large-capacity hydraulic system reacts quickly during operation, and a low-noise control valve increases both efficiency and durability.

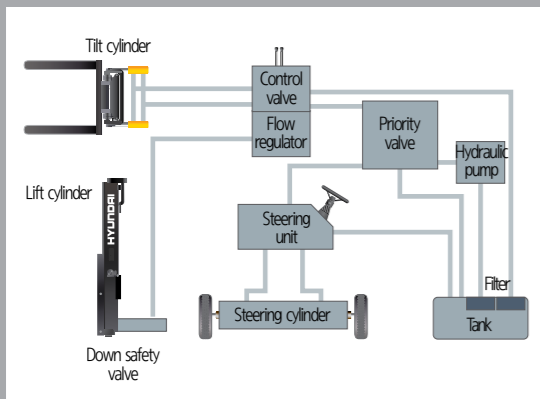

The new master on the job-site!

Smooth running, efficient and ergonomically designed, 15D/18D/20DA-7E series are made to meet your needs.



Some of the photos may include optional equipment.



Fast and stable performance

Being able to quickly raise and lower the mast, as well as tilt it forward and backward, provides the best operational conditions during unloading. When the truck is fully loaded, mast lowering speed is carefully controlled to ensure safety by the down control valve.

Faster travel speed & gradeability

The powerful high-output engine provides greater acceleration, better gradeability and faster travel speed on any tough terrain or slope.

Gradeability (Loaded)		Travel speed (Unloaded)	
15D-7E	20.2°	15D-7E	19.0km/h
18D-7E	18.3°	18D-7E	19.0km/h
20DA-7E	17.2°	20DA-7E	19.1km/h



Increased mast tilting angle

The mast tilting angle of 6 degrees forward and 10 degrees backward, the operator can safely and rapidly perform loading and unloading jobs.



Wet disc brake system

The wet disc brake system is virtually maintenance free and is enclosed to protect from dust and water.



Fully hydrostatic power steering

A hydraulic steering system always guarantees smooth and flexible steering, preventing overrun and kick-back.



Key-locking fuel cap

Increased security on job sites with locking fuel cap, plus an increased capacity fuel tank for less down time.

Comfortable Operation



Adjustable steering wheel
Steering wheel with horn button can be adjusted by a lever on the right-hand side for the most comfortable operator position.



Easy and safe shift lever
A single lever on the left side of the steering column gives the operator fast, easy control of direction.



Multi-function switch lever
Multi-functional switch lever gives easy access to lights and horn.



Quick response of operating control levers
Only minimal operator's effort is required for precise, safe and productive control.



Ergonomically designed with the operator in mind!

A design based on human engineering relieves fatigue and increase operator's efficiency.

Some of the photos may include optional equipment.



Ergonomically positioned pedals
Based on human engineering, the accelerator, brake and inching pedals are optimally positioned for convenience while operating the equipment.

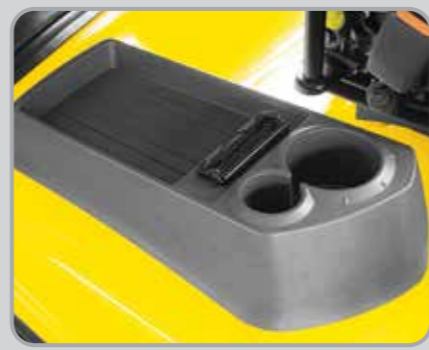

Cup holder & console box
Additional storage spaces are located inside the operating space for operator's convenience.



New high visibility for safe operation
The operator is able to work with increased safety and accuracy due to a wider view mast.

Operator friendly gauges and water-resistant monitor panel

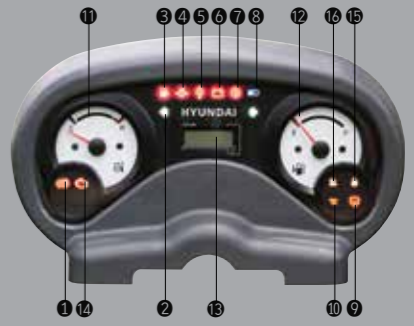

- ① Parking brake lamp
- ② Directional indicators
- ③ Fuel warning lamp
- ④ Engine oil warning lamp
- ⑤ Transmission oil temperature warning lamp
- ⑥ Battery charging warning lamp
- ⑦ Air cleaner filter warning light
- ⑧ Working light indicator
- ⑨ Water separator lamp
- ⑩ Pre-heater indicator
- ⑪ Water temperature gauge
- ⑫ Fuel gauge
- ⑬ Hour meter
- ⑭ Engine check lamp
- ⑮ Seat belt warning
- ⑯ OPS warning

Easily adjustable suspension seat

An attractive and adjustable seat, based on a human engineering design, provides great comfort, safety and durability.



Full floating overhead guard mount

The anti-vibration rubber is installed between the guard and truck frame to reduce the source of vibration and noise while driving. This not only reduces operator's fatigue but also increases safety.



Endurance & Safety

Strong overhead guard

The safety overhead guard exceeds EEC and ANSI regulations and protects the operator during hazardous jobs.



Parking brake

Ratchet type parking brake requires less efforts from the operator to set.



Highly durable split type drive axle

The bevel gear set and hub reduction axle smoothly delivers desired torque to the drive wheels.

Enhanced safety through high durability!

Safety and durability are priorities in the design of the equipment.



Some of the photos may include optional equipment.



Large footboard & hand grip

Wide "open" step offers convenience and safety when entering and exiting truck.

Heavy duty single unit frame

Heavy duty single unit type frame, designed on the basis of accurate structural analysis, guaranteeing durability and safety.

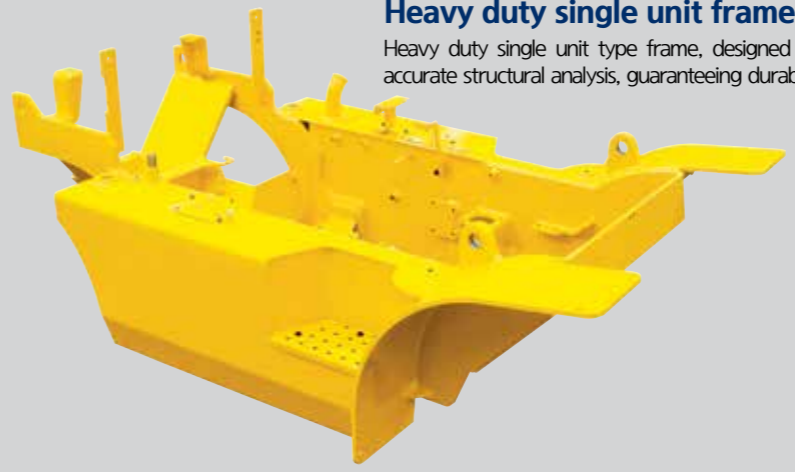

Easy access of electrical Components

Various electric parts are centralized in dash board resulting in improvement in maintenance.



Expansion bellows

The expansion bellows absorbs vibration and reduces noise generated from the exhaust gas system and also extends the life cycle of exhaust gas system.



Bright, protected headlights

Bright, protected headlights is positioned for exceptional visibility.

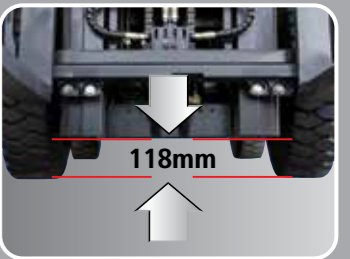

Ground clearance

The engine and transmission are assembled horizontally and positioned high in the frame to protect expansive components during operation on rugged surface.

Durability **Easy** Maintenance



Electrically monitored air filter

Air cleaner sensor alerts the operator of a restricted air filter and allows replacement before damage.



Brake fluid reservoir

Highly visible, easily accessible reservoir makes for quicker daily inspections.



An accessible, compact fuse box for easy inspection



Centralized design for easy service!

An ideal arrangement of component parts ensures easy access and convenience for maintenance.



Easy change air cleaner

The air filter is readily accessible for cleaning or replacement. (7inch Cyclone Type)



Portable side cover



Rotational battery installation

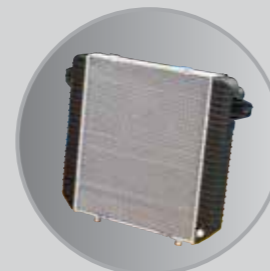

Aluminum radiator with superb protection against heat



Quick and easy engine oil check

Mast Specification

Mast Type	Overall Height Lowered	Maximum Fork Height			Free Lift				Tilt Angle (deg)		Load Capacity w / o Side Shift (500 mm) LC Single Tire			Load Capacity w / Side Shift (500 mm) LC Single Tire			Truck Weight Unload Single Tire		
					With bkr		With / o bkr		Fwd	Bwd	15D-7E	18D-7E	20DA-7E	15D-7E	18D-7E	20DA-7E	15D-7E	18D-7E	20DA-7E
		15D/18D/20DA-7E	15/18D-7E	20DA-7E	15D/18D-7E	20DA-7E	15D/18D-7E	20DA-7E											
V300	2,005	3,025	3,030	145	150	145	150	6	10	1,500	1,750	2,000	1,400	1,650	1,890	2,780	2,950	3,096	
*V330	2,155	3,325	3,330	145	150	145	150	6	10	1,500	1,750	2,000	1,400	1,650	1,890	2,800	2,970	3,116	
V350	2,255	3,525	3,530	145	150	145	150	6	10	1,500	1,750	2,000	1,400	1,650	1,890	2,813	2,983	3,130	
V370	2,355	3,725	3,730	145	150	145	150	6	10	1,500	1,750	1,950	1,400	1,650	1,850	2,827	2,997	3,143	
V400	2,505	4,025	4,030	145	150	145	150	6	10	1,475	1,700	1,550	1,390	1,600	1,470	2,851	3,021	3,168	
V450	2,855	4,525	4,530	145	150	145	150	6	6	1,425	1,625	1,500	1,340	1,535	1,420	2,918	3,088	3,235	
V500	3,105	5,025	5,030	145	150	145	150	6	6	1,350	1,450	1,050	1,270	1,370	980	2,951	3,121	3,268	
V550	3,355	5,525	5,530	145	150	145	150	6	5	1,050	1,000	825	970	930	760	2,972	3,142	3,289	
TF370/TS370	1,805	3,735	3,740	798	803	1,299	1,300	6	6	1,500	1,725	1,900	1,400	1,650	1,810	2,914	3,065	3,221	
TF400/TS400	1,905	4,035	4,040	898	903	1,399	1,400	6	6	1,475	1,675	1,850	1,400	1,610	1,770	2,933	3,084	3,240	
TF430/TS430	2,005	4,335	4,340	998	1,003	1,499	1,500	6	6	1,425	1,625	1,800	1,365	1,560	1,720	2,953	3,103	3,259	
TF450/TS450	2,105	4,535	4,540	1,098	1,103	1,599	1,600	6	6	1,400	1,600	1,700	1,340	1,535	1,620	2,964	3,123	3,279	
TF470/TS470	2,155	4,735	4,740	1,148	1,153	1,649	1,650	6	6	1,375	1,475	1,400	1,315	1,415	1,350	2,984	3,134	3,290	
TF500/TS500	2,255	5,035	5,040	1,248	1,253	1,749	1,750	6	6	1,350	1,425	1,050	1,290	1,370	1,020	3,022	3,154	3,310	
TF550/TS550	2,455	5,535	5,540	1,448	1,453	1,949	1,950	6	5	1,125	1,125	800	1,075	1,085	780	3,094	3,192	3,348	
TF600/TS600	2,655	6,035	6,040	1,648	1,653	2,149	2,150	6	5	775	775	500	750	755	490	3,138	3,264	3,420	
TF650	2,855	6,535	6,540	1,848	1,853	2,349	2,350	3	3	525	525	450	510	510	440	3,174	3,308	3,464	

* Standard

Load Capacity

